

The vision - became reality

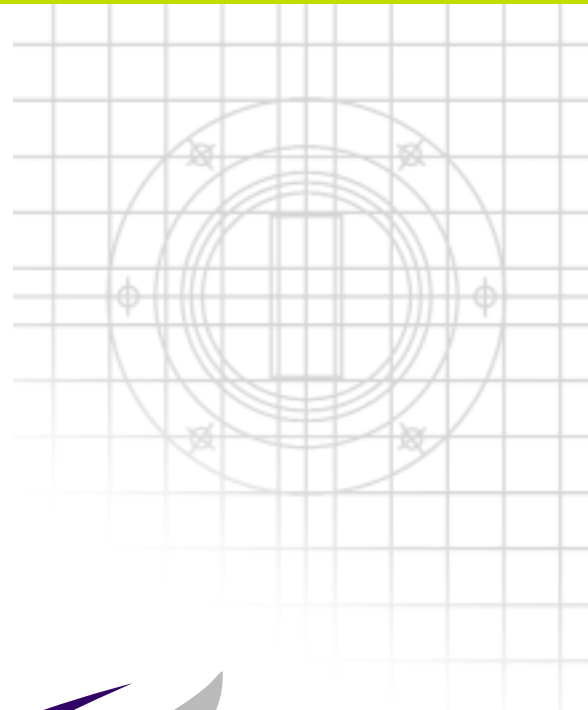
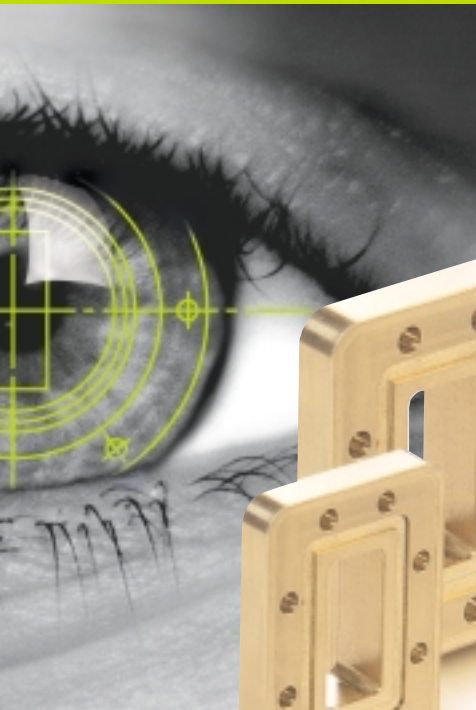

The Supply Solution

Continuous Engineering Quality

the partnership

The Supply Solution Limited (TSS) is an exciting new force in CNC machining, precision engineering, fabrication and waveguide component manufacture.

The company was formed by the coming together of the skills and expertise of many past Quasar Microwave Technology Limited (Quasar) machinists and the CNC precision engineering experience of Harbourne Engineering Limited (Harbourne).

Harbourne was formed in 1990, and proceeded to established itself as a regional heavyweight in its core strength areas of CNC machining, precision engineering and fabrication. At the time of the merger with TSS, Harbourne boasted an impressive array of clients in the aviation and automotive industries.

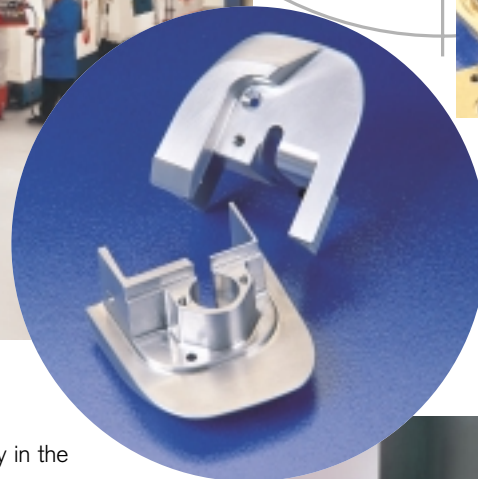
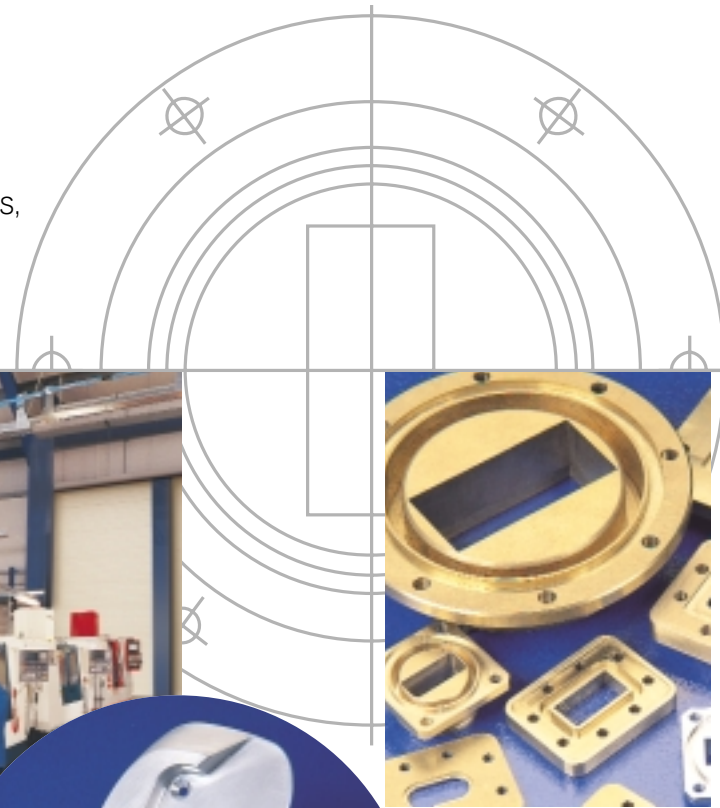

All the skilled staff at Harbourne have been retained and will continue to work from the 5,000 square foot purpose built facility in the Heathfield area of Newton Abbot. The newly constructed premises houses an impressive 12 CNC machining centres, including milling centres, machining & turning centres. The latest acquisition of a Bridgeport VMC1000 with a 12,000 rpm spindle further enhances the companies

capabilities. TSS's intention is to expand by investing in additional high speed, high accuracy machines over the next year. All machines will be supported by state of the art CAD/CAM systems which enables TSS to compete for the most sophisticated CNC machine work.





TSS aims to be the preferred supplier in the following core areas:

WAVEGUIDE COMPONENTS

In order to service one of the leading waveguide manufacturers in the world, Quasar put in place an impressive machining facility which concentrated on mass producing waveguide accessories. TSS inherited a number of key Quasar staff to support its' goal of becoming market leader in the manufacture of these components.

Mike Jackson Managing Director and former Director of Quasar comments, "The synergy between both entities is very exciting - the experience and skills base of our staff combined with the facilities at Harbourne strategically places us in an excellent position to become market leader. The ethos of the company - one of including all members in the success of the business - has proved a major driving force in allowing us to achieve a long standing ambition of entering the waveguide component market."

CNC MACHINING & FABRICATION

TSS will build on the success of Harbourne in the aviation, automotive and related markets.

Ben Cartridge Sales Director and former Productions Manager at Quasar explains, "Our aim is to open up our capabilities to other clients in these areas whilst cross selling our products to existing clients of The Solution Group. Our customer service and responsiveness will provide the added value which we believe will set us aside from our competitors."

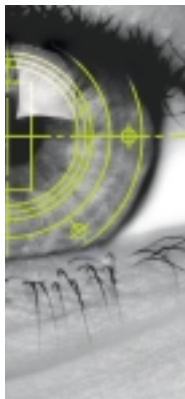

delivering the vision

Customer Service

TSS will develop its business through excellence in customer service.

One of the key elements needed to achieve this is to maintain a skilled and motivated workforce.

TSS includes staff in the success of the business and recognises personal development and, to this end, works in partnership with local colleges as part of the modern apprenticeship scheme.



Quality

TSS has recently been awarded ISO 9001:2000. The company is currently working to achieve ISO14001.



No.17539

Agents

The company has an extensive network of worldwide agents providing an instant and effective sales team to service your needs.

The Supply Solution

SALES REPRESENTATIVES

Benelux

Mr Ton Van Breukelen
Semi Dice International BV
Middel 6, 1551 Sp Westzaan, Netherlands
Telephone: 00 31 75 647 6969
Fax: 00 31 75 640 8795
breukelen@semidice.nl

China (Hong Kong)

Mr Edward Lo
Tect Electronics
Flat 811, 8F, Hing Wah Centre,
82-84 Tokwawan Road, Kowloon, Hong Kong, China
Telephone: 00852 2333 7679
Fax: 00852 2333 7176
edward@tect.com.hk

China (Shang Hai)

Ms Jenny Wang
Tect Electronics
802, 8F., Tomson Financial Building,
710 Dong Fang Road,
Pudong, Shanghai 200122, China
Telephone: 008621 5830 5389
Fax: 008621 5830 5387
tectsh@sh163b.sta.net.cn

Czech Republic

Mr Vitezslav Roucek, Mr Michal Narovec
Afro-Bohemia Ltd
Narodni 10, 113 19 Prague, Czech Republic
Telephone: 00 420 2 838 52425
Fax: 00 420 2 838 50319
afro-bohemia@seznam.cz

Finland

Mr Seppo Kytala
Aseko OY
Electronics Division, Tinankuja 3, FIN-02430,
Masala, Finland
Telephone: 00 358 10 400 1321
Fax: 00 358 10 400 1200
seppo.kytala@aseko.fi

France

Mr Alexandre Gerby, Mr Laurent Vanitou
Milmega S.A
195 Avenue du General Leclerc, BP 47,
78221 Viroflay, France
Telephone: 00 33 1 30 24 77 18
Fax: 00 33 1 30 24 75 92
alexandre.gerby@milmega.fr laurent.vanitou@milmega.fr

Germany / Austria / Switzerland

Mr Hans Brunner, Mr Tom Salitz, Mr Thomas Wiesner
Omecon Electronic GmbH
Raiffeisenstrasse 12, D-83607, Holzirchen, Germany
Telephone: 00 49 8024 64080
Fax: 00 49 8024 640870
abc@omecon.de

India

Mr Andy Khandwala
Syratron Marketing Private Ltd
203 Copper Arch,
83 Infantry Road, Bangalore 560 01, India
Telephone: 00 9180 559 1107 / 559 1031
Fax: 00 9180 5591056
andy@syratron.com

Indonesia

Mr Hartono Wibowo
PT. Lembayung
Graha Ekacitta Bld, J.L. Budi Raya No: 9 Kemanggisan,
Jakarta 11530 - Indonesia
Telephone: 00 62 21 549 0641 / 532 8140 / 532 8141
Fax: 00 62 21 530 5593 / 830 8550
harw@centrin.net.id

Israel

Mr Avi Vardy
Rfcell Technologies Ltd
25 Hasochnut Street, Hod Hasharon 45264, Israel
Telephone: 00 972 67 77 30 77
Fax: 00 972 9 7404716
avi@rfcell.com

Italy

Mr Diego Carraro
CELTE S.R.L.
Via Gobetti 2/A, 20063 Cernusco S/N, Milan, Italy
Telephone: 00 39 02 921 08020
Fax: 00 39 02 921 08088
d.carraro@celte-srl.com

Mr Diego Carraro

CELTE S.R.L.
Via Capunan 22, 00137 Roma, Italy
Telephone: 00 39 06 / 8277664
Fax: 00 39 06 868 01952
d.carraro@celte-srl.com

Norway

Mr Jonny Tvedt
Odd Tvedt & Co AS
Damsgardsvai 59, PO box 2356, 5058 Bergen, Norway
Telephone: 00 47 55 59 98 90
Fax: 00 47 55 59 98 99
jonny.tvedt@oddtvedt.no

Poland

Mr Krzysztof Walicki, Mr Marius Koterebinski
Gesco s.c.,
Av.Dzieci Polskich 19A,
04-730 Warsaw, Poland
Telephone: 00 48 22 815 60 32
Fax: 00 48 22 613 34 14
info@gesco.pl

South Korea

Mr Hoi Kyung, Lim
Hirok-Tech (HK International)
4th Floor Taeseong B/D, 1530-2, Seocho-Dong,
Seocho-Gu, Seoul, 137-070 Korea
Telephone: 00 82 2 3471 1750/1
Fax: 00 82 2 3471 1752
hkl@hirok.co.kr

Spain / Portugal

Mr Jose Gonzales Morena, Mr Julio Torrecilla
Redislogar SA
C/Lanzarote 2, Poligono Industrial Norte,
28700 San Sebastian De Los Reyes, Madrid, Spain
Telephone: 00 34 91 659 00 63
Fax: 00 34 91 659 14 36
jgm@redislogar.es
j.torrecilla@redislogar.es

Sweden

Mr Kees van Doorn, Mr Niklas van Doorn
Amska,
Amerikanska Teleprodukter AB, PO Box 88,
155 21 Nykvarn, Sweden
Telephone: 00 46 8 55 490 950
Fax: 00 46 8 55 490 951
kvd@amska.se

Turkey

Mr Abdullah Saglam
SVS Telecom
Kosuyolu, Ali Nazemin Sok. No: 15,
Kadikoy-Istanbul, Turkey
Telephone: 00 90 216 326 6266
Fax: 00 90 216 326 6638
asaglam@svstelekom.com.tr

Taiwan

Mr Allen Dan
Jeso System Corporation
12F, No 174, Zhong-Shan Rd. Sec. 1,
Yung-Ho City, Taipei Hsien 234, Taiwan.
Telephone: 00 886(02)29251560
Fax: 00 886(02)22323871
jso88com@ms3.hinet.net

your move...

For further information or to find out more about how
TSS can help your business contact:



The Supply Solution Limited

King Charles Business Park,
Old Newton Road,
Heathfield,
Newton Abbot,
Devon TQ12 6UT

T: +44 (0) 1626 835515

F: +44 (0) 1626 835513

E: enquires@supplysolution.co.uk

W: www.supplysolution.co.uk

